

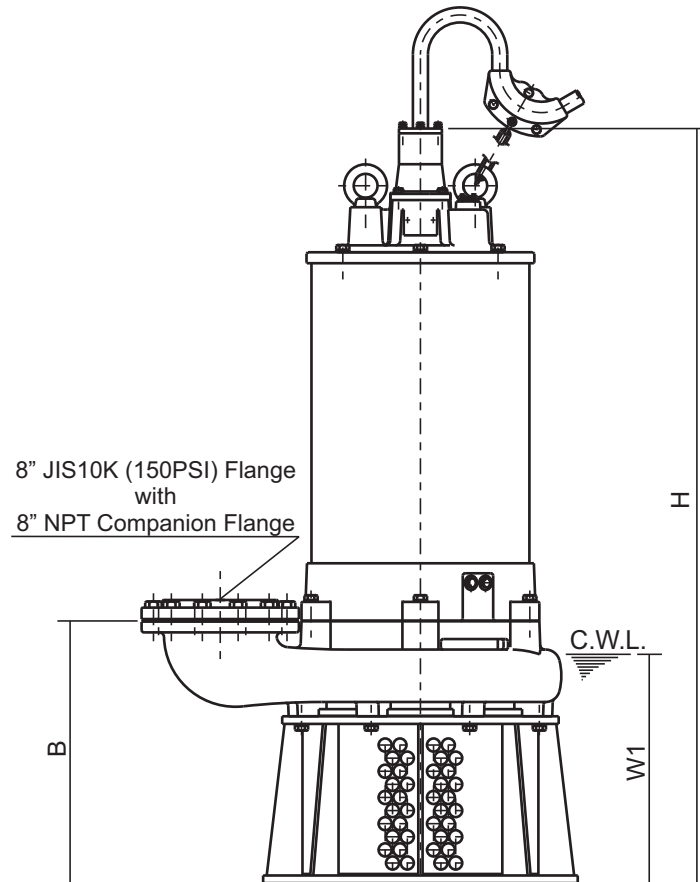

GSZ-4 SERIES
HIGH VOLUME - DEWATERING PUMPS

DIMENSIONS

GSZ5-37-4

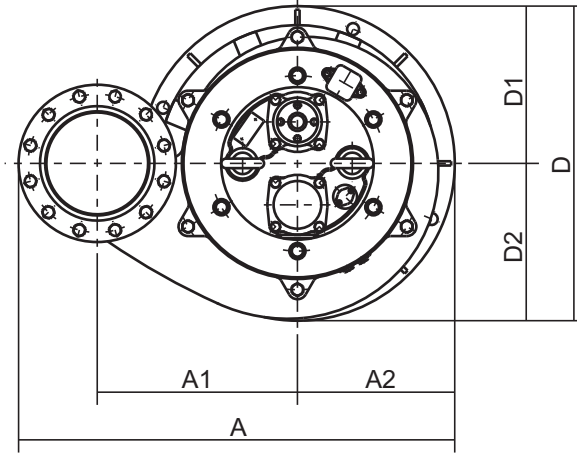

8" JIS10K (150PSI) Flange with 8" NPT Companion Flange

C.W.L. : Continuous running Water Level

DIMENSIONS:USCS (Inch)

Model	HP	NOM. SIZE	Pump & Motor								C.W.L.		*Wt. (lbs.)
			A	A1	A2	B	D	D1	D2	H	W1		
GSZ5-37-4	50	8"	36	16 9/16	13	21 5/8	26	13	13	62 5/16	18 7/8	1240	

*Excluding Cable

DIMENSIONS:METRIC (mm)

Model	kW	NOM. SIZE	Pump & Motor								C.W.L.		*Wt. (kg)
			A	A1	A2	B	D	D1	D2	H	W1		
GSZ5-37-4	37	200	915	420	330	550	660	330	330	1583	480	565	



GSZ-4 SERIES HIGH VOLUME - DEWATERING PUMPS

PERFORMANCE CURVE

MODEL	BORE	HP	KW	RPM	SOLIDS DIA	LIQUID	SG.	VISCOSITY	TEMP.
GSZ5-37-4	8"/200mm	50	37	1750	0.984"/25mm	Water	1.0	1.123 cSt	60°F
PUMP TYPE		PHASE	VOLTAGE	AMPERAGE		HZ	STARTING METHOD		INS. CLASS
High Volume - Dewatering Pump		3	460/575	63 / 49.5		60	Direct On Line		F
CURVE No.	DATE	PHASE	VOLTAGE	AMPERAGE		HZ	STARTING METHOD		INS. CLASS
-	-	-	-	-		-	-		-

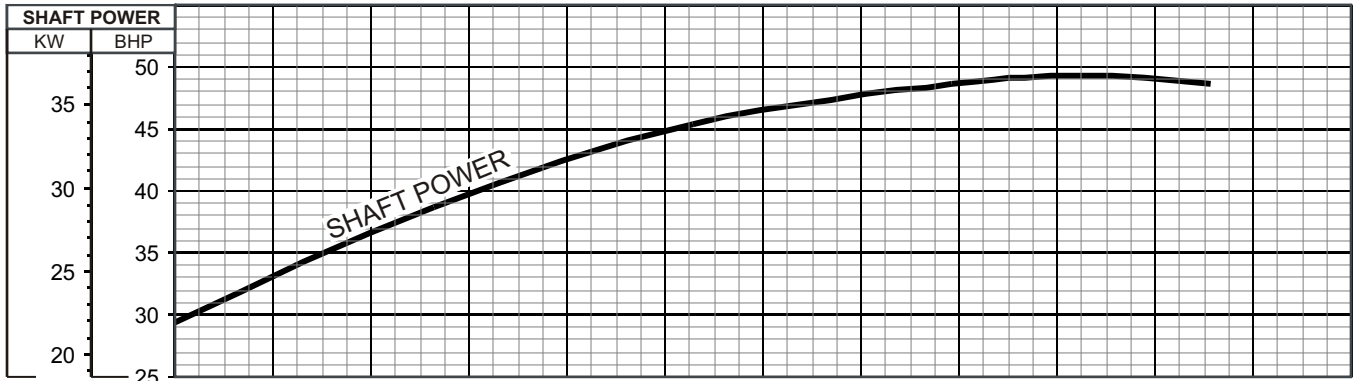
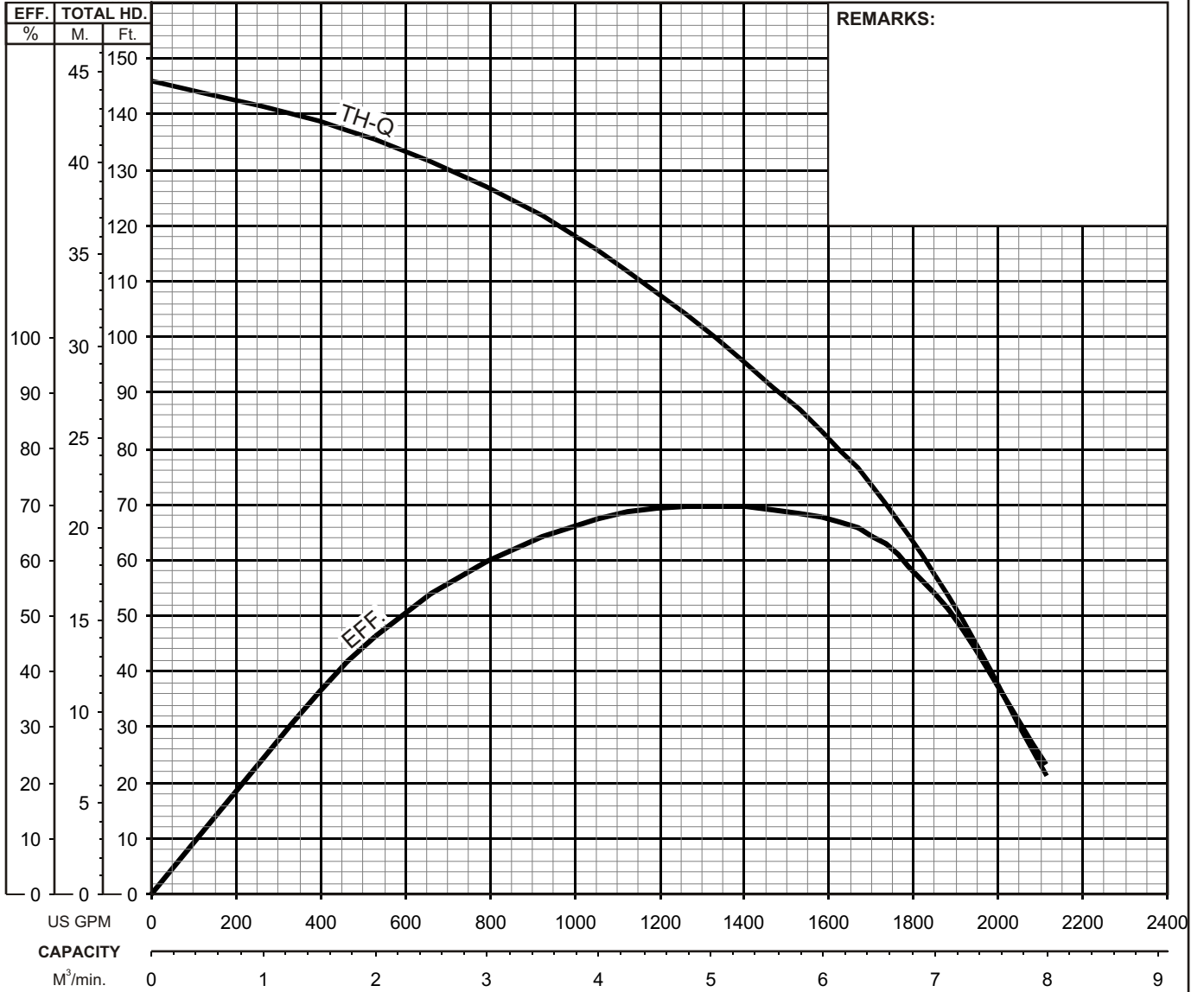



GSZ-4 SERIES
HIGH VOLUME - DEWATERING PUMP

SECTIONAL VIEW

GSZ5-37-4

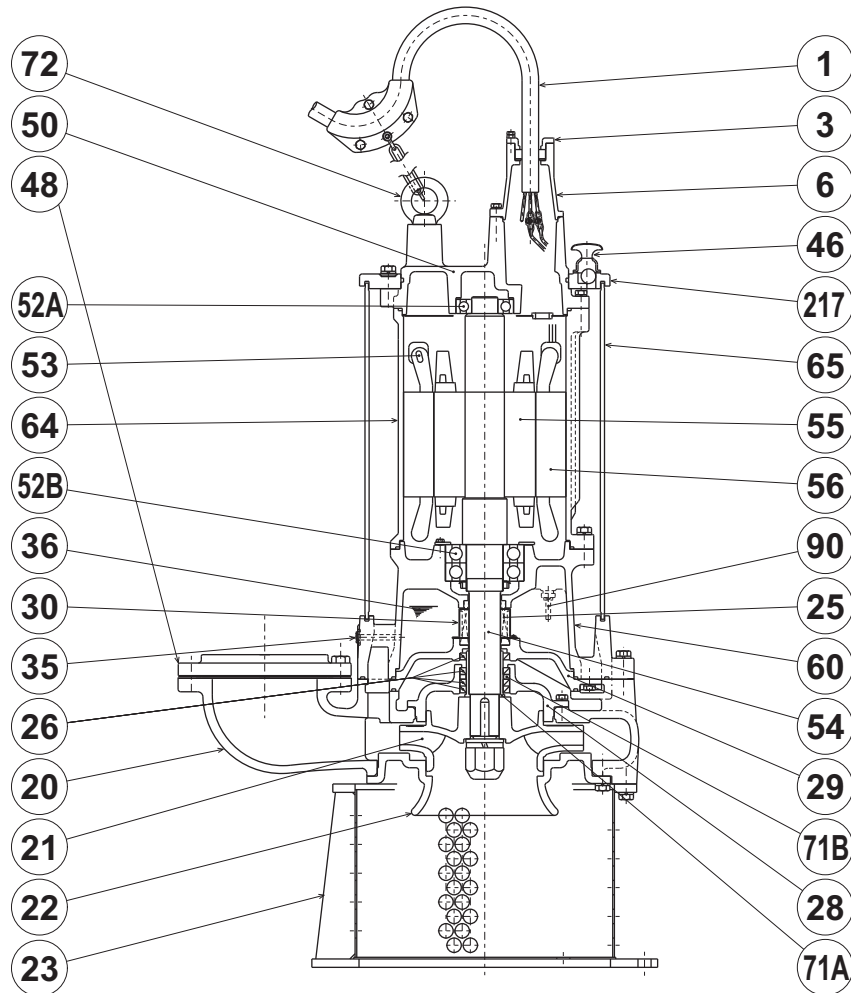

ITEM#	DESCRIPTION	MAIN MATERIAL / NOTE	ASTM, AISI CODE	RELATED EN CODE	Q'TY
1	Power Cable	Chloroprene Sheath AWG 2/3, 6/1, 14/3 - 50ft			1
3	Gland	Cast Iron	A48M Class30B	EN 1561 GJL-200	1
6	Stuffing Box	Cast Iron	A48M Class30B	EN 1561 GJL-200	1
20	Pump Casing	Cast Iron	A48M Class30B	EN 1561 GJL-200	1
21	Impeller	High Chrome Cast Iron	A532 ClassIIITypeA	DIN 1695 G-X260Cr27	1
22	Suction Cover	Cast Iron	A48M Class30B	EN 1561 GJL-200	1
23	Suction Strainer	Steel	A283 Grade D	EN 10025 S275	1
25	Mechanical Seal	Silicon Carbide / H-60			1
26	Oil Seal	NBR / TC-709513			4
28	Seal Housing	Cast Iron	A48M Class30B	EN 1561 GJL-200	1
29	Oil Casing	Cast Iron	A48M Class30B	EN 1561 GJL-200	1
30	Oil Lifter	Steel (Cold Rolled)	A109/A1008	EN 10130	1
35	Oil Plug	Stainless Steel	S 30400	1.4301	2
36	Lubricant	Turbine Oil ISO VG32 or SAE 10W-20			
46	Air Release Valve	Steel (Cold Rolled)	A109/A1008	EN 10130	1
48	Companion Flange	Cast Iron / NPT8" JIS10K	A48M Class30B	EN 1561 GJL-200	1
50	Motor Bracket	Cast Iron	A48M Class30B	EN 1561 GJL-200	1
52A	Upper Bearing	#6310ZZC3			1
52B	Lower Bearing	#6314ZZD2C3			1
53	Motor Protector				3
54	Shaft	Stainless Steel	S 42000	1.4021	1
55	Rotor				1
56	Stator				1
60	Bearing Housing	Cast Iron	A48M Class30B	EN 1561 GJL-200	1
64	Motor Housing	Cast Iron	A48M Class30B	EN 1561 GJL-200	1
65	Outer Cover	Steel Pipe	A53 Type F	DIN 1615 St 33	1
71A	Shaft Sleeve	Stainless Steel	S 40300	1.4000	1
71B	Spacer	Stainless Steel	S 40300	1.4000	1
72	Lifting Lug Bolt	Steel	A283 Grade D	EN 10025 S275	2
90	Leak Sensor (Electrode)	Stainless Steel	S 30300	1.4305	1
217	Fixing Plate	Cast Iron	A48M Class30B	EN 1561 GJL-200	1

PARTS LIST		HIGH VOLUME DEWATERING PUMP			3/9/2017	
ITEM	PART No.	DESCRIPTION	QTY	SIZE	MATERIAL	NOTES
1	009-113-17	Terminal	3	R-38-10	CU	
2	009-107-18	Terminal	1	R-14-6	CU	
3	009-116-10	Terminal	3	R-2-4	CU	
4	010-103-21	Cable Clip	2	No.4	SPC	
5	140-074-15	Hex.Bolt	3	M10x20	SUS304	
6	141-006-19	Hex.Nut	3	M10	SUS304	
7	001-002-57	Cabletyre Cable (Sold per meter)	15	2PNCTFMulti-core7Cx30mm2(d34.1)	(Vm)	
8	010-129-10	Cable Clip Rubber	1	115x100x2t	NBR	
9	140-058-42	Hex.Bolt	4	M8x40	SUS304	
10	141-005-18	Hex.Nut	4	M8	SUS304	
11	003-106-19	Gland	1	No.5	FC	
12	004-000-08	Cable Bush	1	d34.5xd58x27L	NBR	
13	140-076-17	Hex.Bolt	4	M10x30	SUS304	
14	142-164-19	Spring Washer	4	M10	SUS304	
15	006-000-08	Stuffing Box	1	GSZ3-22-6	FC	
16	122-132-16	O-Ring	1	G-105(104.4xd3.1)	NBR	*
17	009-107-18	Terminal	1	R-14-6	CU	
18	140-029-28	Hex.Bolt	1	M6x10	SWRM	
19	009-114-18	Connector	2	PC-4020M		
20	009-114-18	Connector	1	PC-4020M		
21	009-115-19	Connector	1	PC-4020F		
22	009-115-19	Connector	2	PC-4020F		
23	141-004-59	Hex.Nut	4	M6	SWRM	
24	009-167-16	Terminal	3	R-38-S6	CU	
25	009-107-18	Terminal	6	R-14-6	CU	
26	140-030-35	Hex.Bolt	3	M6x12	SWRM	
27	002-128-14	Heat Shrink Tube (Sold per meter)	m	EVA(d10x1t)	(Vm)	
27A	002-164-12	Heat Shrink Tube (Sold per meter)	m	A4(d13x0.3t)	(Vm)	
28	200-000-16	Electrical tape	1	N tape(0.5x19x10M)		
28	200-000-17	Electrical tape	1	S tape(0.2x19x10M)		
28	002-140-12	Heat Shrink Tube (Sold per meter)	m	ST-110DG(d19)	(Vm)	
28	002-163-11	Heat Shrink Tube Silicon Rubber	m	ST-80DG		
28	200-000-10	Insulating Tape	m	W=25,T=0.18		
29	143-041-12	Pan Screw	1	M6x8	SWRM	
30	009-107-18	Terminal	2	R-14-6	CU	
31	140-076-17	Hex.Bolt	4	M10x30	SUS304	
32	142-164-19	Spring Washer	4	M10	SUS304	
33	214-008-10	Blind Cover	1		FC	
34	122-132-16	O-Ring	1	G-105(104.4xd3.1)	NBR	*

* Indicates items included in set

PARTS LIST		HIGH VOLUME DEWATERING PUMP			3/9/2017	
ITEM	PART No.	DESCRIPTION	QTY	SIZE	MATERIAL	NOTES
35	140-427-17	Hex.Bolt (w/Plain Washer)	2	M5x15	SUS304	
36	003-175-19	Blind Cover	1	LB	SUS304	
37	121-000-01	Packing (Blind Cover)	1	LB	NBR	
38	011-101-19	Shackle	1	6mm	SS	
39	095-100-18	Chain	1	d5(9-Link)	SS	
40	072-000-30	Eye Bolt	2	M24	SS	
41	140-052-17	Hex.Bolt	2	M8x16	SUS304	
42	142-163-18	Spring Washer	2	M8	SUS304	
43	046-000-05	Air Release Valve	1	GSZ/NKZ/B	SPCC	
44	121-151-18	Packing	1	P.C.80xd50	CR	*
45	203-058-11	Ball	1	d28	SS	
46	140-102-13	Hex.Bolt	6	M12x55	SUS304	
47	142-165-10	Spring Washer	6	M12	SUS304	
48	142-000-47	Washer	6	M12(d12.5xd25.5x5t)	SUS304	
49	121-513-12	Seal Packing	6	d11.5xd21x4t	CR	*
50	217-000-21	Fixing Plate	1	GSZ-37/45KW,U-30/37KW	FC	
51	122-359-11	O-Ring	1	445xd5.7	NBR	*
52	122-353-15	O-Ring	1	310xd5.7	NBR	*
53	140-100-11	Hex.Bolt	6	M12x45	SUS304	
54	142-165-10	Spring Washer	6	M12	SUS304	
55	035-113-18	Air Tightness Test Plug	1	M12x14	SUS304	
56	121-247-12	Packing	1	d12.3xd18x2t	PE	*
57	050-000-75	Motor Bracket	1		FC	
58	122-353-15	O-Ring	1	310xd5.7	NBR	*
59	142-000-73	Wave Washer	1	6310(d109xd92x7Hx1.2t)	SK5	
60	052-000-50	Bearing (w/O-ring)	1	AC-6310ZZC3		
61	016-000-04	Lead Wire Protection Bush	2	d21xd52x11t	SBR	
62	058-000-23	Lead Wire Protection Plate	1	d120xd315x3t	SPCC	
63	065-000-53	Outer Cover	1		SGP	
64	055-001-96	Rotor	1Set			
65	147-000-38	Impeller Key	1	16x10x65L	SUS420	
66	053-001-67	Motor Protector	3	YS11A135A-D20	(H)	
67	056-005-42	Stator 460V-60Hz(USA)	1Set			
67	056-005-43	Stator 575V-60Hz(USA)	1Set			
68	064-000-99	Motor Frame	1		FC	
69	140-128-15	Hex.Bolt	6	M16x60	SUS304	
70	142-166-11	Spring Washer	6	M16	SUS304	
71	142-427-13	Seal Washer	2	WD-12	SPC+NBR	
72	140-000-69	Hex.Bolt	2	M12x25	SS	

PARTS LIST		HIGH VOLUME DEWATERING PUMP			3/9/2017	
ITEM	PART No.	DESCRIPTION	QTY	SIZE	MATERIAL	NOTES
73	122-308-15	O-Ring	1	320xd5.7	NBR	*
74	140-000-68	Hex.Bolt	4	M8x20	SS	
75	062-000-14	Bearing Fixing Plate	1	6314(d130xd190x4.5t)	SS	
76	052-145-12	Bearing	1Set	6314ZZD2C3		
77	142-247-17	Bearing Washer	1	AW14	SPCC	
78	141-079-13	Bearing Nut	1	AN14	SS	
79	122-359-11	O-Ring	1	445xd5.7	NBR	*
80	140-130-10	Hex.Bolt	6	M16x70	SUS304	
81	142-166-11	Spring Washer	6	M16	SUS304	
82	060-001-50	Bearing Housing	1		FC	
83	122-259-10	O-Ring	2	12xd3	NBR	*
84	035-102-30	Oil Plug	2	M12x16(B=21)	SUS304	
85	122-266-10	O-Ring	1	460xd6	NBR	*
86	090-122-11	Leakage Sensor(Electrode)/w Gland	1Set	d9x43L	SUS	
87	142-161-32	Spring Washer	2	M5	SWRH	
88	140-000-67	Hex.Bolt	2	M5x20	SS	
89	025-000-51	Mechanical Seal	1	H-60	SiC	
90	143-028-13	Pan Screw	3	M5x10	SWRM	
91	030-134-10	Oil Lifter	1	H-60	SPCC	
92	122-265-19	O-Ring	1	335xd5.7	NBR	*
93	029-200-14	Oil Casing	1	300-BH	FC	
94	122-314-14	O-Ring	1	341xd5.7	NBR	*
95	142-165-10	Spring Washer	6	M12	SUS304	
96	140-098-15	Hex.Bolt	6	M12x35	SUS304	
97	026-118-15	Oil Seal	1	TC-709513	NBR	
98	140-096-13	Hex.Bolt	6	M12x25	SUS304	
99	142-165-10	Spring Washer	6	M12	SUS304	
100	028-000-15	Seal Housing	1	GSZ3-37-4(H)	FC	
101	122-299-12	O-Ring	1	260xd3.8	NBR	*
102	071-000-32	Spacer	1	d72xd95x9t	SUS403	
103	026-118-15	Oil Seal	3	TC-709513	NBR	
104	071-000-13	Shaft Sleeve	1	GSZ3-37-4(H)	SUS403	
105	037-150-13	Flanged Discharge Pipe	1Set	200mm(GSZ-37-4)	SGP	
106	140-148-11	Hex.Bolt	8	M20x50	SUS304	
107	142-168-13	Spring Washer	8	M20	SUS304	
108	121-166-29	Packing	1	JIS5Kx200mm	NR	
109	020-342-25	Pump Casing	1	GSZ2-37-4(JIS5K-200A)	FC	
110	021-002-31	Impeller (60Hz)	1	GSZ5-37-4	HiCrFC	
111	142-136-12	Plain Washer	1	M42	SUS304	

PARTS LIST		HIGH VOLUME DEWATERING PUMP			3/9/2017	
ITEM	PART No.	DESCRIPTION	QTY	SIZE	MATERIAL	NOTES
112	142-173-11	Spring Washer	1	M42	SUS304	
113	157-007-19	Impeller Nut	1	M42,P4.5,H=60	SS	
114	122-315-15	O-Ring	1	405xd5	NBR	*
115	022-178-24	Suction Cover	1	GSZ-37-4	FC	
116	142-166-11	Spring Washer	8	M16	SUS304	
117	140-124-11	Hex.Bolt	8	M16x40	SUS304	
118	023-185-14	Strainer Stand	1	GSZ-37-4	SS	
119	142-166-11	Spring Washer	8	M16	SUS304	
120	140-124-11	Hex.Bolt	8	M16x40	SUS304	
121	140-155-11	Hex.Bolt	12	M20x85	SUS304	
122	048-000-52	Screwed Flange	1	NPT-8(JIS10K)	FC	
123	121-109-24	Packing	1	JIS10Kx200mm	NR	
124	142-168-13	Spring Washer	12	M20	SUS304	
125	141-009-12	Hex.Nut	12	M20	SUS304	
	173-000-89	Packing O-Ring Set	1Set	(Marked by *)		
16	122-132-16	O-Ring (S.Box)	1	G-105(104.4xd3.1)	NBR	*
34	122-132-16	O-Ring (Blind Cover)	1	G-105(104.4xd3.1)	NBR	*
44	121-151-18	Packing (Air Release Valve)	1	P.C.80xd50	CR	*
49	121-513-12	Seal Packing (Fixing Plate Bolt)	6	d11.5xd21x4t	CR	*
51	122-359-11	O-Ring (Fixing Plate/Out.Cover)	1	445xd5.7	NBR	*
52	122-353-15	O-Ring (Fixing Plate/M.Bracket)	1	310xd5.7	NBR	*
56	121-247-12	Packing (Air Tightness Test Plug)	1	d12.3xd18x2t	PE	*
58	122-353-15	O-Ring (M.Bracket/M.Frame)	1	310xd5.7	NBR	*
73	122-308-15	O-Ring (M.Frame/Brg.Housing)	1	320xd5.7	NBR	*
79	122-359-11	O-Ring (Out.Cover/Brg.Housing)	1	445xd5.7	NBR	*
83	122-259-10	O-Ring (Oil Plug)	2	12xd3	NBR	*
85	122-266-10	O-Ring (Brg.Housing/P.Casing)	1	460xd6	NBR	*
92	122-265-19	O-Ring (Brg.Housing/O.Casing)	1	335xd5.7	NBR	*
94	122-314-14	O-Ring (O.Casing/P.Casing)	1	341xd5.7	NBR	*
101	122-299-12	O-Ring (Seal Housing/P.Casing)	1	260xd3.8	NBR	*
108	121-166-29	Packing (Discharge Pipe/P.Casing)	1	JIS5Kx200mm	NR	*
114	122-315-15	O-Ring (P.Casing/S.Cover)	1	405xd5	NBR	*
123	121-109-24	Packing (Flanged/Discharge Pipe)	1	JIS10Kx200mm	NR	*
		Lubricant		Turbine Oil VG32 8,800ml		

PARTS LIST		HIGH VOLUME DEWATERING PUMP			3/9/2017	
ITEM	PART No.	DESCRIPTION	QTY	SIZE	MATERIAL	NOTES

EXPLODED VIEW

GSZ5-37-4 (JIS5K)

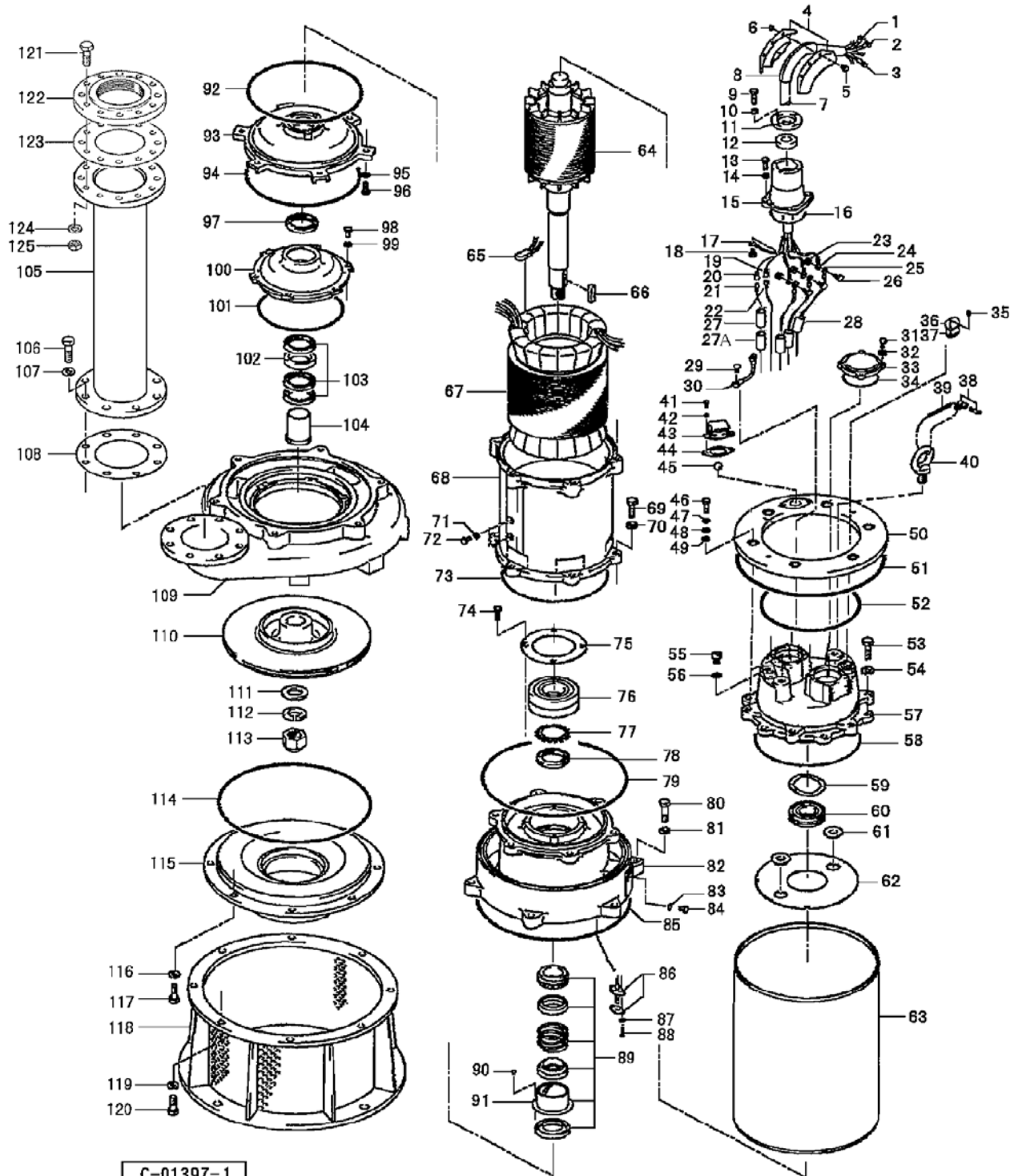

PARTS LIST		HIGH VOLUME DEWATERING PUMP			3/10/2017	
ITEM	PART No.	DESCRIPTION	QTY	SIZE	MATERIAL	NOTES
1	009-113-17	Terminal	3	R-38-10	CU	
2	009-107-18	Terminal	1	R-14-6	CU	
3	009-116-10	Terminal	3	R-2-4	CU	
4	010-103-21	Cable Clip	2	No.4	SPC	
5	140-074-15	Hex.Bolt	3	M10x20	SUS304	
6	141-006-19	Hex.Nut	3	M10	SUS304	
7	001-002-57	Cabtyre Cable (Sold per meter)	15	2PNCTFMulti-core7Cx30mm2(d34.1)	(Vm)	
8	010-129-10	Cable Clip Rubber	1	115x100x2t	NBR	
9	140-058-42	Hex.Bolt	4	M8x40	SUS304	
10	141-005-18	Hex.Nut	4	M8	SUS304	
11	003-106-19	Gland	1	No.5	FC	
12	004-000-08	Cable Bush	1	d34.5xd58x27L	NBR	
13	140-076-17	Hex.Bolt	4	M10x30	SUS304	
14	142-164-19	Spring Washer	4	M10	SUS304	
15	006-000-08	Stuffing Box	1	GSZ3-22-6	FC	
16	122-132-16	O-Ring	1	G-105(104.4xd3.1)	NBR	*
17	009-107-18	Terminal	1	R-14-6	CU	
18	140-029-28	Hex.Bolt	1	M6x10	SWRM	
19	009-114-18	Connector	2	PC-4020M		
20	009-114-18	Connector	1	PC-4020M		
21	009-115-19	Connector	1	PC-4020F		
22	009-115-19	Connector	2	PC-4020F		
23	141-004-59	Hex.Nut	4	M6	SWRM	
24	009-167-16	Terminal	3	R-38-S6	CU	
25	009-107-18	Terminal	6	R-14-6	CU	
26	140-030-35	Hex.Bolt	3	M6x12	SWRM	
27	002-128-14	Heat Shrink Tube (Sold per meter)	m	EVA(d10x1t)	(Vm)	
27A	002-164-12	Heat Shrink Tube (Sold per meter)	m	A4(d13x0.3t)	(Vm)	
28	200-000-16	Electrical tape	1	N tape(0.5x19x10M)		
28	200-000-17	Electrical tape	1	S tape(0.2x19x10M)		
28	002-140-12	Heat Shrink Tube (Sold per meter)	m	ST-110DG(d19)	(Vm)	
28	002-163-11	Heat Shrink Tube Silicon Rubber	m	ST-80DG		
28	200-000-10	Insulating Tape	m	W=25,T=0.18		
29	143-041-12	Pan Screw	1	M6x8	SWRM	
30	009-107-18	Terminal	2	R-14-6	CU	
31	140-076-17	Hex.Bolt	4	M10x30	SUS304	
32	142-164-19	Spring Washer	4	M10	SUS304	
33	214-008-10	Blind Cover	1		FC	

PARTS LIST		HIGH VOLUME DEWATERING PUMP			3/10/2017	
ITEM	PART No.	DESCRIPTION	QTY	SIZE	MATERIAL	NOTES
34	122-132-16	O-Ring	1	G-105(104.4xd3.1)	NBR	*
35	140-427-17	Hex.Bolt (w/Plain Washer)	2	M5x15	SUS304	
36	003-175-19	Blind Cover	1	LB	SUS304	
37	121-000-01	Packing (Blind Cover)	1	LB	NBR	
38	011-101-19	Shackle	1	6mm	SS	
39	095-100-18	Chain	1	d5(9-Link)	SS	
40	072-000-30	Eye Bolt	2	M24	SS	
41	140-052-17	Hex.Bolt	2	M8x16	SUS304	
42	142-163-18	Spring Washer	2	M8	SUS304	
43	046-000-05	Air Release Valve	1	GSZ/NKZ/B	SPCC	
44	121-151-18	Packing	1	P.C.80xd50	CR	*
45	203-058-11	Ball	1	d28	SS	
46	140-102-13	Hex.Bolt	6	M12x55	SUS304	
47	142-165-10	Spring Washer	6	M12	SUS304	
48	142-000-47	Washer	6	M12(d12.5xd25.5x5t)	SUS304	
49	121-513-12	Seal Packing	6	d11.5xd21x4t	CR	*
50	217-000-21	Fixing Plate	1	GSZ-37/45KW,U-30/37KW	FC	
51	122-359-11	O-Ring	1	445xd5.7	NBR	*
52	122-353-15	O-Ring	1	310xd5.7	NBR	*
53	140-100-11	Hex.Bolt	6	M12x45	SUS304	
54	142-165-10	Spring Washer	6	M12	SUS304	
55	035-113-18	Air Tightness Test Plug	1	M12x14	SUS304	
56	121-247-12	Packing	1	d12.3xd18x2t	PE	*
57	050-000-75	Motor Bracket	1		FC	
58	122-353-15	O-Ring	1	310xd5.7	NBR	*
59	142-000-73	Wave Washer	1	6310(d109xd92x7Hx1.2t)	SK5	
60	052-000-50	Bearing (w/O-ring)	1	AC-6310ZZC3		
61	016-000-04	Lead Wire Protection Bush	2	d21xd52x11t	SBR	
62	058-000-23	Lead Wire Protection Plate	1	d120xd315x3t	SPCC	
63	065-000-53	Outer Cover	1		SGP	
64	055-001-96	Rotor	1Set			
65	147-000-38	Impeller Key	1	16x10x65L	SUS420	
66	053-001-67	Motor Protector	3	YS11A135A-D20	(H)	
67	056-005-42	Stator 460V-60Hz(USA)	1Set			
67	056-005-43	Stator 575V-60Hz(USA)	1Set			
68	064-000-99	Motor Frame	1		FC	
69	140-000-69	Hex.Bolt	2	M12x25	SS	
70	142-427-13	Seal Washer	2	WD-12	SPC+NBR	

PARTS LIST		HIGH VOLUME DEWATERING PUMP			3/10/2017	
ITEM	PART No.	DESCRIPTION	QTY	SIZE	MATERIAL	NOTES
71	142-166-11	Spring Washer	6	M16	SUS304	
72	140-128-15	Hex.Bolt	6	M16x60	SUS304	
73	122-308-15	O-Ring	1	320xd5.7	NBR	*
74	140-000-68	Hex.Bolt	4	M8x20	SS	
75	062-000-14	Bearing Fixing Plate	1	6314(d130xd190x4.5t)	SS	
76	052-145-12	Bearing	1Set	6314ZZD2C3		
77	142-247-17	Bearing Washer	1	AW14	SPCC	
78	141-079-13	Bearing Nut	1	AN14	SS	
79	122-359-11	O-Ring	1	445xd5.7	NBR	*
80	140-130-10	Hex.Bolt	6	M16x70	SUS304	
81	142-166-11	Spring Washer	6	M16	SUS304	
82	060-001-50	Bearing Housing	1		FC	
83	122-259-10	O-Ring	2	12xd3	NBR	*
84	035-102-30	Oil Plug	2	M12x16(B=21)	SUS304	
85	122-266-10	O-Ring	1	460xd6	NBR	*
86	090-122-11	Leakage Sensor(Electrode)/w Gland	1Set	d9x43L	SUS	
87	142-161-32	Spring Washer	2	M5	SWRH	
88	140-000-67	Hex.Bolt	2	M5x20	SS	
89	025-000-51	Mechanical Seal	1	H-60	SiC	
90	143-028-13	Pan Screw	3	M5x10	SWRM	
91	030-134-10	Oil Lifter	1	H-60	SPCC	
92	122-265-19	O-Ring	1	335xd5.7	NBR	*
93	029-200-14	Oil Casing	1	300-BH	FC	
94	122-314-14	O-Ring	1	341xd5.7	NBR	*
95	142-165-10	Spring Washer	6	M12	SUS304	
96	140-098-15	Hex.Bolt	6	M12x35	SUS304	
97	026-118-15	Oil Seal	1	TC-709513	NBR	
98	140-096-13	Hex.Bolt	6	M12x25	SUS304	
99	142-165-10	Spring Washer	6	M12	SUS304	
100	028-000-15	Seal Housing	1	GSZ3-37-4(H)	FC	
101	122-299-12	O-Ring	1	260xd3.8	NBR	*
102	071-000-32	Spacer	1	d72xd95x9t	SUS403	
103	026-118-15	Oil Seal	3	TC-709513	NBR	
104	071-000-13	Shaft Sleeve	1	GSZ3-37-4(H)	SUS403	
105	020-003-20	Pump Casing	1	GSZ5-37-4(JIS10K-200A)	FC	
106	021-002-31	Impeller (60Hz)	1	GSZ5-37-4	HiCrFC	
107	142-136-12	Plain Washer	1	M42	SUS304	
108	142-173-11	Spring Washer	1	M42	SUS304	

PARTS LIST		HIGH VOLUME DEWATERING PUMP			3/10/2017	
ITEM	PART No.	DESCRIPTION	QTY	SIZE	MATERIAL	NOTES
109	157-007-19	Impeller Nut	1	M42,P4.5,H=60	SS	
110	122-315-15	O-Ring	1	405xd5	NBR	*
111	022-178-24	Suction Cover	1	GSZ-37-4	FC	
120	142-168-13	Spring Washer	12	M20	SUS304	
112	142-166-11	Spring Washer	8	M16	SUS304	
113	140-124-11	Hex.Bolt	8	M16x40	SUS304	
114	023-185-14	Strainer Stand	1	GSZ-37-4	SS	
115	142-166-11	Spring Washer	8	M16	SUS304	
116	140-124-11	Hex.Bolt	8	M16x40	SUS304	
117	140-171-13	Hex.Bolt	12	M20x55	SUS304	
118	142-168-13	Spring Washer	12	M20	SUS304	
119	048-000-52	Screwed Flange	1	NPT-8(JIS10K)	FC	
200	121-109-24	Packing	1	JIS10Kx200mm	NR	
	173-000-88	Packing O-Ring Set	1Set	(Marked by *)		
16	122-132-16	O-Ring (S.Box)	1	G-105(104.4xd3.1)	NBR	*
34	122-132-16	O-Ring (Blind Cover)	1	G-105(104.4xd3.1)	NBR	*
44	121-151-18	Packing (Air Release Valve)	1	P.C.80xd50	CR	*
49	121-513-12	Seal Packing (Fixing Plate Bolt)	6	d11.5xd21x4t	CR	*
51	122-359-11	O-Ring (Fixing Plate/Out.Cover)	1	445xd5.7	NBR	*
52	122-353-15	O-Ring (Fixing Plate/M.Bracket)	1	310xd5.7	NBR	*
56	121-247-12	Packing (Air Tightness Test Plug)	1	d12.3xd18x2t	PE	*
58	122-353-15	O-Ring (M.Bracket/M.Frame)	1	310xd5.7	NBR	*
73	122-308-15	O-Ring (M.Frame/Brg.Housing)	1	320xd5.7	NBR	*
79	122-359-11	O-Ring (Out.Cover/Brg.Housing)	1	445xd5.7	NBR	*
83	122-259-10	O-Ring (Oil Plug)	2	12xd3	NBR	*
85	122-266-10	O-Ring (Brg.Housing/P.Casing)	1	460xd6	NBR	*
92	122-265-19	O-Ring (Brg.Housing/O.Casing)	1	335xd5.7	NBR	*
94	122-314-14	O-Ring (O.Casing/P.Casing)	1	341xd5.7	NBR	*
101	122-299-12	O-Ring (Seal Housing/P.Casing)	1	260xd3.8	NBR	*
110	122-315-15	O-Ring (P.Casing/S.Cover)	1	405xd5	NBR	*
200	121-109-24	Packing (Flanged /P.Casing)	1	JIS10Kx200mm	NR	*
		Lubricant		Turbine Oil VG32 8,800ml		

PARTS LIST		HIGH VOLUME DEWATERING PUMP			3/10/2017	
ITEM	PART No.	DESCRIPTION	QTY	SIZE	MATERIAL	NOTES

EXPLODED VIEW

GSZ5-37-4 (JIS10K)

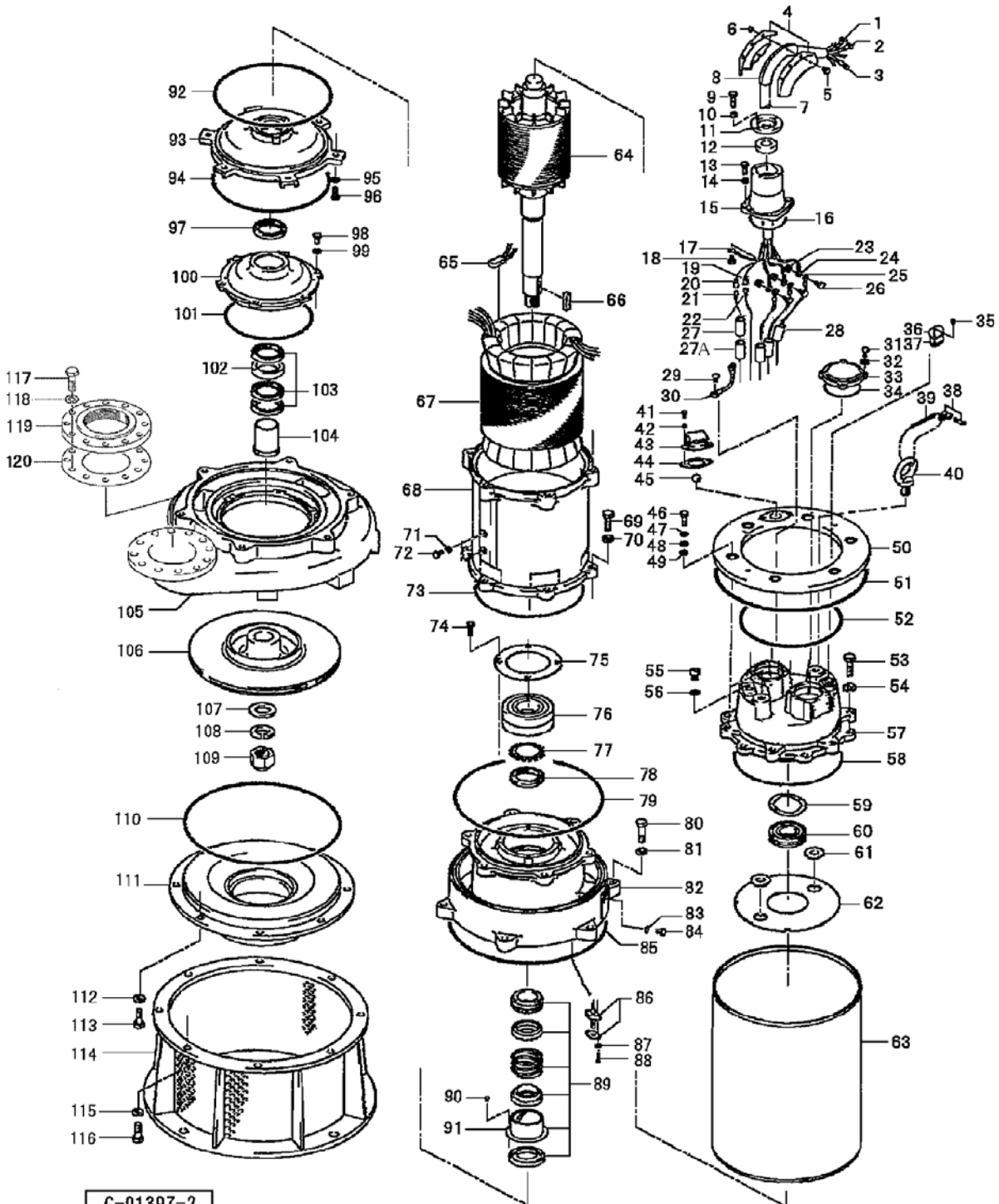

C-01397-2